



OR10H400M (FB)

HALF CELL LINE



The 108 Half Cut module of the Import Line combines the high production efficiency of the half cell technology with an excellent quality / price ratio.

The half-cell configuration improves the electrical distribution inside the panel to increase the yield of the product. For these reasons, the Half Cell Line is suitable not only for industrial installations but also for residential and commercial installations.

30 YEAR LINEAR POWER WARRANTY
25 YEAR PRODUCT WARRANTY



PERC TECHNOLOGY



PID FREE



MODULE FIRE PERFORMANCE: **CLASS 1**



ANTI-REFLECTIVE GLASS



QBE INSURANCE
Product Liability Insurance QBE

Cells



108 CELLS
MONO 9BB / 10BB M10 HALF | PERC

182 x 91 mm / 7.16 x 3.58"

Frame



COMPACT AND STURDY | 30 mm

ANCHORABLE ALSO ON
THE SHORT SIDE ⁽³⁾

Electrical Characteristics (STC) ⁽¹⁾

Nominal Output (Pmax) ⁽²⁾	400 W
Sorting Tolerance	0/+5 W
Voltage at Pmax (Vmp)	31.2 V
Current at Pmax (Imp)	12.82 A
Open Circuit Voltage (Voc) ⁽²⁾	37.2 V
Short Circuit Current (Isc) ⁽²⁾	13.57 A
Maximum System Voltage	1500 V
Maximum Series Fuse Rating	25 A
Module Efficiency	20.48%
Protection class against electric shock	Class II

Mechanical Characteristics

Solar Cells	108 M10 HALF monocrystalline PERC
Solar Cells Size	182 x 91 mm / 7.16 x 3.58"
Front Cover	3.2 mm / 0.13" thick, low iron tempered glass
Back Cover	TPT (Tedlar-PET-Tedlar)
Encapsulant	EVA (Ethylene vinyl acetate)
Frame	Anodized aluminium alloy, double wall
Frame finishing	Black
Backsheet finishing	Black
Diodes	3 Bypass diodes serviceable
Junction Box	IP67 rated
Connector	MC4 or compatible connector
Cables Length	1100 mm / 43.30"
Cables Section	4.0 mm ² / 0.006 in ²
Dimensions	1722 x 1134 x 30 mm / 67.79 x 44.64 x 1.18"
Weight	21.8 Kg / 48.06 lbs
Max Load (Test Load) - SF	5400 Pa - 1.5" ⁽³⁾

Dimensions

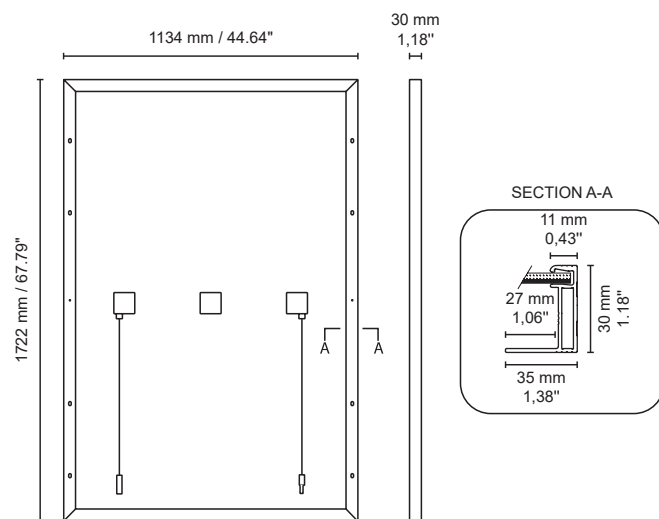

1. STC: (Standard Test Condition) Irradiance 1000W/m², Module Temperature 25°C, Air Mass 1.5

2. Pmax, Voc, Isc measurement tolerance: ±3%

3. NMOT: Nominal Module Operating Temperature. Irradiance 800W/m², Air 20°C, Wind speed 1m/s

OR10H400M (FB)

Nominal Output (Pmax) ⁽²⁾	400 W
Sorting Tolerance	0/+5 W
Voltage at Pmax (Vmp)	31.2 V
Current at Pmax (Imp)	12.82 A
Open Circuit Voltage (Voc) ⁽²⁾	37.2 V
Short Circuit Current (Isc) ⁽²⁾	13.57 A
Maximum System Voltage	1500 V
Maximum Series Fuse Rating	25 A
Module Efficiency	20.48%
Protection class against electric shock	Class II

Temperature Characteristics

NMOT ⁽³⁾	45±2 °C
Temperature Coefficient of Pmax	-0.37 %/°C
Temperature Coefficient of Voc	-0.28 %/°C
Temperature Coefficient of Isc	0.042 %/°C
Operating Temperature	-40 °C - +85°C

Packaging ⁽⁴⁾

Pallet dimensions	1765 x 1120 x 1275 mm / 69.49 x 44.09 x 50.20"
Pieces per pallet	36
Weight	830 kg / 1829.84 lbs

Certifications

Fire Resistance Rating	Class of reaction to fire 1 (UNI g177)
PID free	TUV PPP 58042B:2015 - IEC 62804-1:2015
Salt mist	IEC 61701:2011
Ammonia	IEC 62716:2013
Dust and Sand	TUV PPP 59022B:2021 - IEC 60068-2-68:1994
Product Certificate	IEC 61215-1, IEC 61215-1-1, IEC 61215-2, IEC 61730-1, IEC 61730-2

Current/Voltage Characteristics

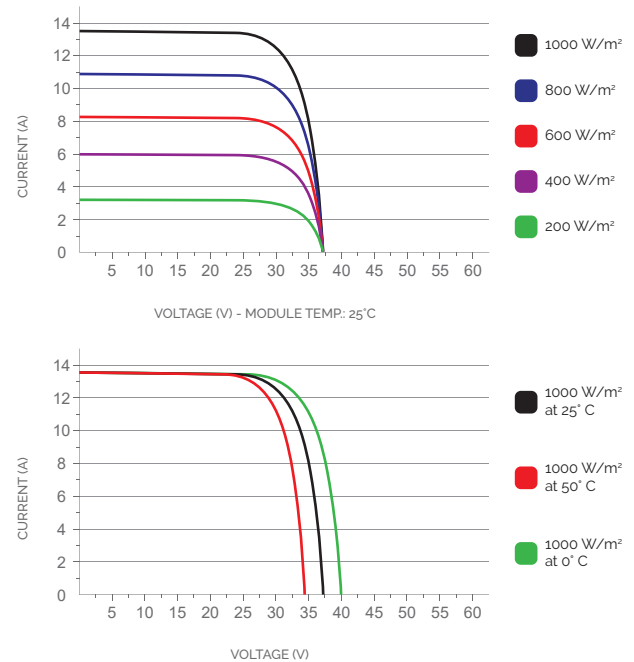

4. Pallets can be stacked up to two

5. Consult the installation manual for the relative mounting configurations